

MODEL 86 5psi

316L SS Pressure Sensor
High Performance, Small Profile
0-100 mV Output
Absolute and Gage
Low Pressure

- Medical Instruments
- Process Control
- Oceanography
- Refrigeration/Compressors
- Pressure Transmitters
- Level Systems



DESCRIPTION

The Model 86 is a small profile, media compatible, piezoresistive silicon pressure sensor packaged in a 316L stainless steel housing. The Model 86 is designed for O-ring mounting. The sensing package utilizes silicon oil to transfer pressure from the 316L stainless steel diaphragm to the sensing element.

The Model 86 is designed for high performance, low pressure applications. A ceramic substrate is attached to the package that contains laser-trimmed resistors for temperature compensation and offset correction. An additional laser-trimmed resistor is included which can be used to adjust an external differential amplifier and provide span interchangeability to within $\pm 1\%$.

Sensors with threaded pressure fittings, weldable flush sensors and high pressure stainless steel sensors are also available. Please contact the factory for more information.

DIMENSIONS

FEATURES

- O-ring Flush Mount
- 0°C To +50°C Compensated Temperature Range
- $\pm 0.1\%$ Pressure Non-linearity
- +1.0% Interchangeable Span (provided by gain set resistor)
- Solid State Reliability
- Low Power

STANDARD RANGES

Range	psig	psia
0 to 5	•	•

SENSING ELEMENT

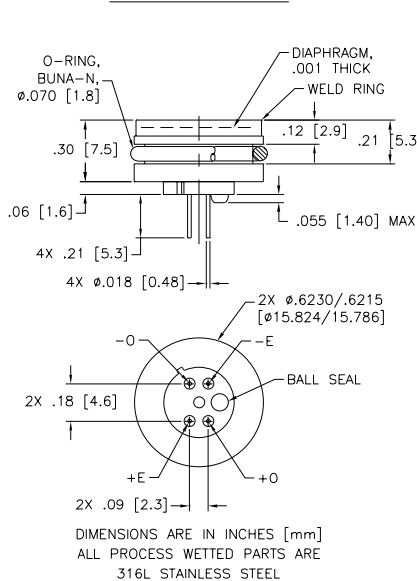

w/OPTIONS

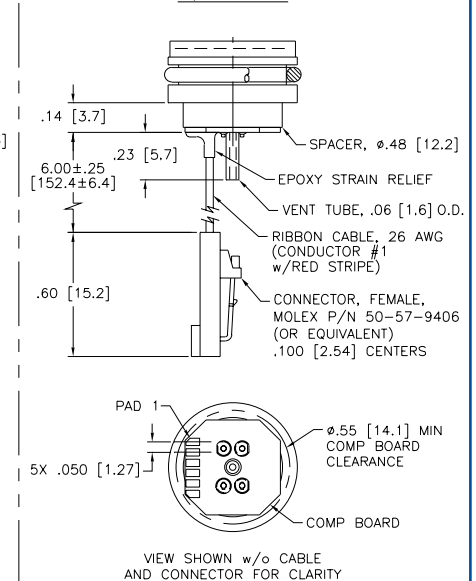

Internet: www.msusa.com
 Tel: 1-757-766-1500
 North America Toll Free: 1-800-745-8008
 Fax: 1-757-766-4297

PERFORMANCE SPECIFICATIONS

All parameters measured at 1.5mA drive and at 25°C after 10 second warm up, unless otherwise specified. Unless specifically indicated, only those parameters indicated as tested are verified on each part. Parameters are specified for the compensated version only.

PARAMETERS	MIN	TYP	MAX	UNITS	NOTES
Full Scale Output Span	50	100	150	mV	1.2
Zero Offset	-1	0	1	mV	2
Pressure Non-linearity	-0.10		0.10	% Span	3
Pressure Hysteresis	-0.1		0.1	% Span	
Input Resistance	3500		6000	Ω	
Output Resistance	4000		25000	Ω	
Temperature Error - Span	-0.75		1.5	% Span	4
Temperature Error - Zero	-1.5		1.5	% Span	4
Thermal Hysteresis - Span	-0.25		0.25	% Span	4
Thermal Hysteresis - Zero	-0.25		0.25	% Span	4
Long Term Stability of Offset		0.1		$\pm\%$ Span/yr.	
Long Term Stability of Span		0.1		$\pm\%$ Span/yr.	
Supply Current	0.5	1.5	2.0	mA	5
Output Load Resistance	5			M Ω	6
Insulation Resistance (50 VDC)	50			M Ω	7
Pressure Overload			3X	Rated	
Compensated Operating Temperature	0°C to 50°C				8
Operating Temperature Range	-40°C to +125°C				8
Storage Temperature Range	-50°C to +125°C				8
Media - Pressure Port	Liquids and Gases compatible with 316L Stainless Steel				
Media - Reference Port	Compatible with Silicon, Pyrex, Gold, Fluorosilicon Rubber and 316L Stainless Steel				
Weight	13 grams				

Notes

- For amplified output circuits, 3.012V \pm 1% interchangeability with gain set resistor. See Application Note TN-003.
- Measured at vacuum for absolute (A), ambient for gage (G).
- Best fit straight line.
- Over Temperature range: 0°C to 50°C Span with respect to +25°C.
- Guarantees output/input ratiometricity.
- Load resistance to reduce measurement errors due to output loading.
- Between case and sensing element.
- Maximum temperature range for product with standard cable and connector is -20°C to +105°C.
- For gage units used at pressures below atmosphere, the span accuracy is not guaranteed.
- Standard gauge units are not recommended for vacuum applications. For vacuum applications below 1/2 atmosphere, contact factory.

ORDERING INFORMATION

86 - 005 G - C T

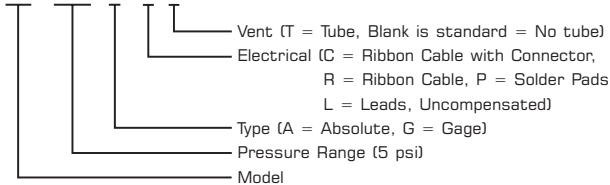

For other ranges, process fittings and electrical connections contact factory.

CONNECTIONS

Rad. No./Cable	Function
1	+OUT
2	-EX
3	+EX
4	-OUT
5	GAIN
6	GAIN

APPLICATION SCHEMATIC

